

*FREE SHIPPING ON ORDERS OVER \$98 (EXCLUSIONS APPLY)



SHOP CATEGORIES

WHY S&B

SHOP BY VEHICLE



CONTACT & SUPPORT



0

CONTACT US



**CONTACT
&
SUPPORT**



S&B AI AGENT

(Order Status, Knowledge Base, & more)



EMAIL



TEXT

(909) 947-0015



CALL

(909) 947-0015

Est. Wait: 2 min

BEFORE YOU START

VEHICLE FITMENT:

2008-2010 Ford 6.4L Powerstroke

DEVICE NAME: Intercooler Boots

Please read the entire product guide before proceeding. Ensure all parts are present. If you are missing any of the components, call our customer support at (909) 947-0015. Do not work on your vehicle while the engine is hot. Make sure the engine is turned off and the vehicle is in Park or the Parking Brake is set.

REQUIRED TOOLS

11mm Deep Socket, torque wrench Flat Blade Screwdriver, P

Note: Approximate Install Time: 2 Hr 00 Mins.

Cookie Preferences

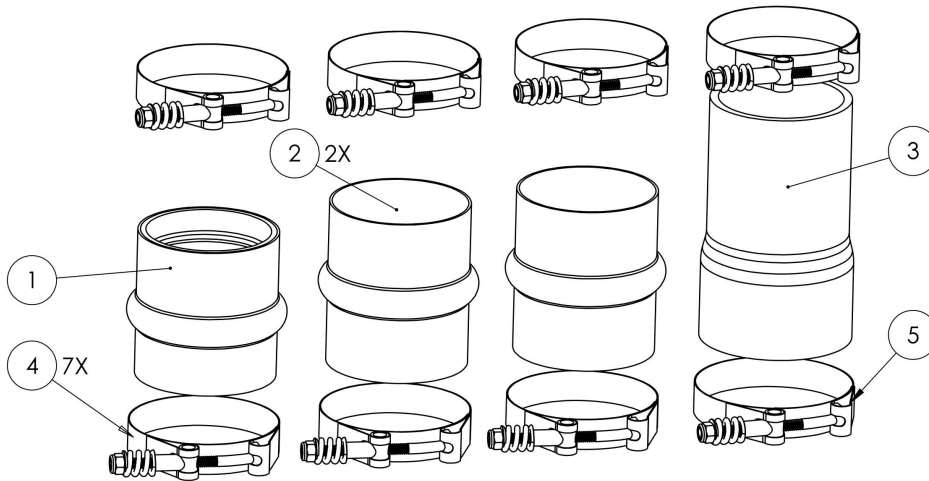

ITEM NO.	PART NUMBER	DESCRIPTION	QTY.
1	AI3467-00	Boot, 3.0" ID x 3.6" Long, Hump w/ Inner Bead	1
2	AI2697-00	Boot, 3.0"ID x 4.0" Long, Hump w/ Inner Bead	2
3	AI2695-00	Boot, Straight, Reducer, 3.125" ID x 2.875" ID x 6.0" Long	1
4	AG1053-00	T-Bolt Hose Clamp, Spring Loaded, 79-87mm, 300 Series	7
5	AG1060-00	T-bolt Hose Clamp, spring loaded, 3.38" in to 3.69"	1

STEP 1

Disconnect Battery.
 Disconnect the negative battery cable by loosening the terminal clamp and removing it from the battery post.

Cookie Preferences

Tool Needed: 10mm Wrench
or Socket.



STEP 2

Loosen the hot side t-bolt
clamps and remove the
factory boots. (passenger
side)

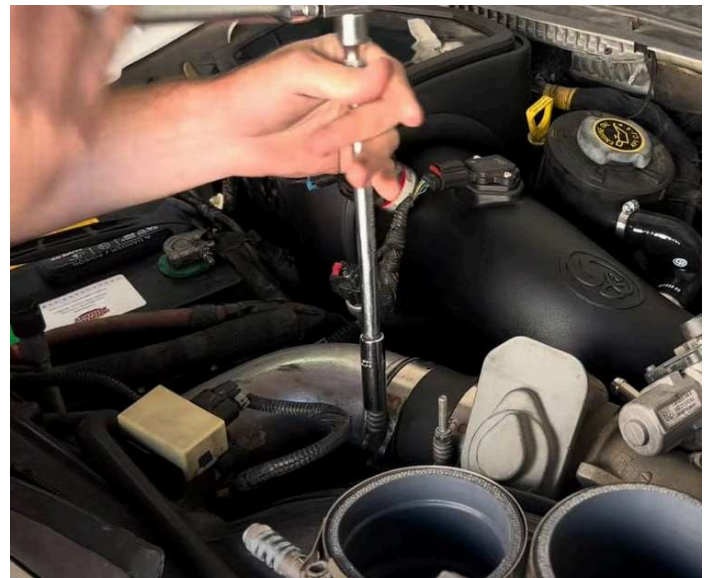

STEP 3

Using a screwdriver can help
break the coupler away from
the intercooler pipe

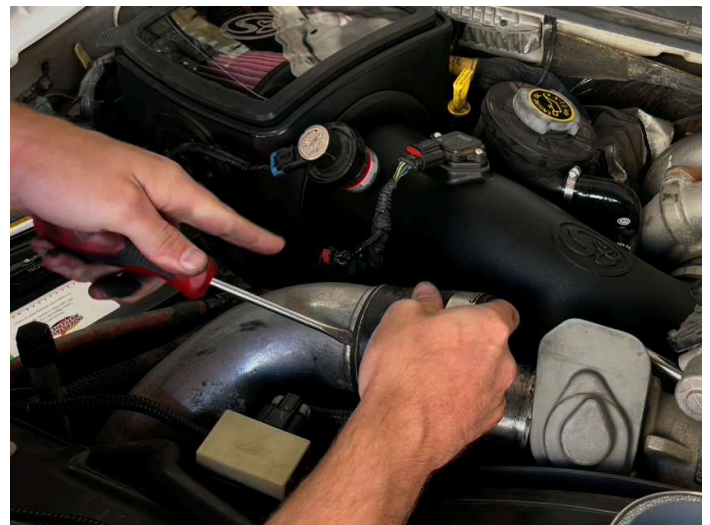

STEP 4

Before installing the S&B boots, clean off the intercooler and manifold.



STEP 5

Install AI3467-00 onto to intercooler pipe/intake manifold. The bead indexes into the intercooler pipe and the shorter side goes onto the manifold.

STEP 6

Install AI2695-00 onto the intercooler & pipe. The

[Cookie Preferences](#)

groove goes onto the intercooler pipe.

STEP 7

Break the t-bolt clamps apart and install around both the upper and lower hot side boots. Torque to 60 in/lbs and make sure the t-bolt clamp is around the groove on the pipe side. The t-bolt camps should be pointing higher on the intercooler side to prevent the clamps from hitting the hood.

STEP 8

Loosen the cold side t-bolts and remove the boots. Again using a flathead if necessary.

STEP 9

Clean off the oil from the surfaces. We used brakleen

STEP 10

Install the S&B boots onto the upper side of the cold side intercooler pipe with the bead into the groove on the pipe. Install the t-bolt clamps onto the pipe and torque to 60 in/lbs

[Cookie Preferences](#)

STEP 11

Remove the lower intercooler boot. Oil may have pooled up in this boot. Wear eye protection.

STEP 12

Clean off the surface off the surfaces of the pipe and intercooler flange

STEP 13

Install the long S&B boot with the bead indexing into the intercooler pipe groove. The bigger side of the boot goes onto the intercooler side. The bigger t-bolt clamp goes onto the intercooler flange side. Break free the t-bolt clamps then torque to 60 in/lbs

FINAL CHECKLIST

Reconnect the battery.
Confirm each clamp has been
torqued and check for hood
clearance on the front
intercooler boot

Cookie Preferences